

COMPONENT PARTS OF KS-21 SAW UNIT

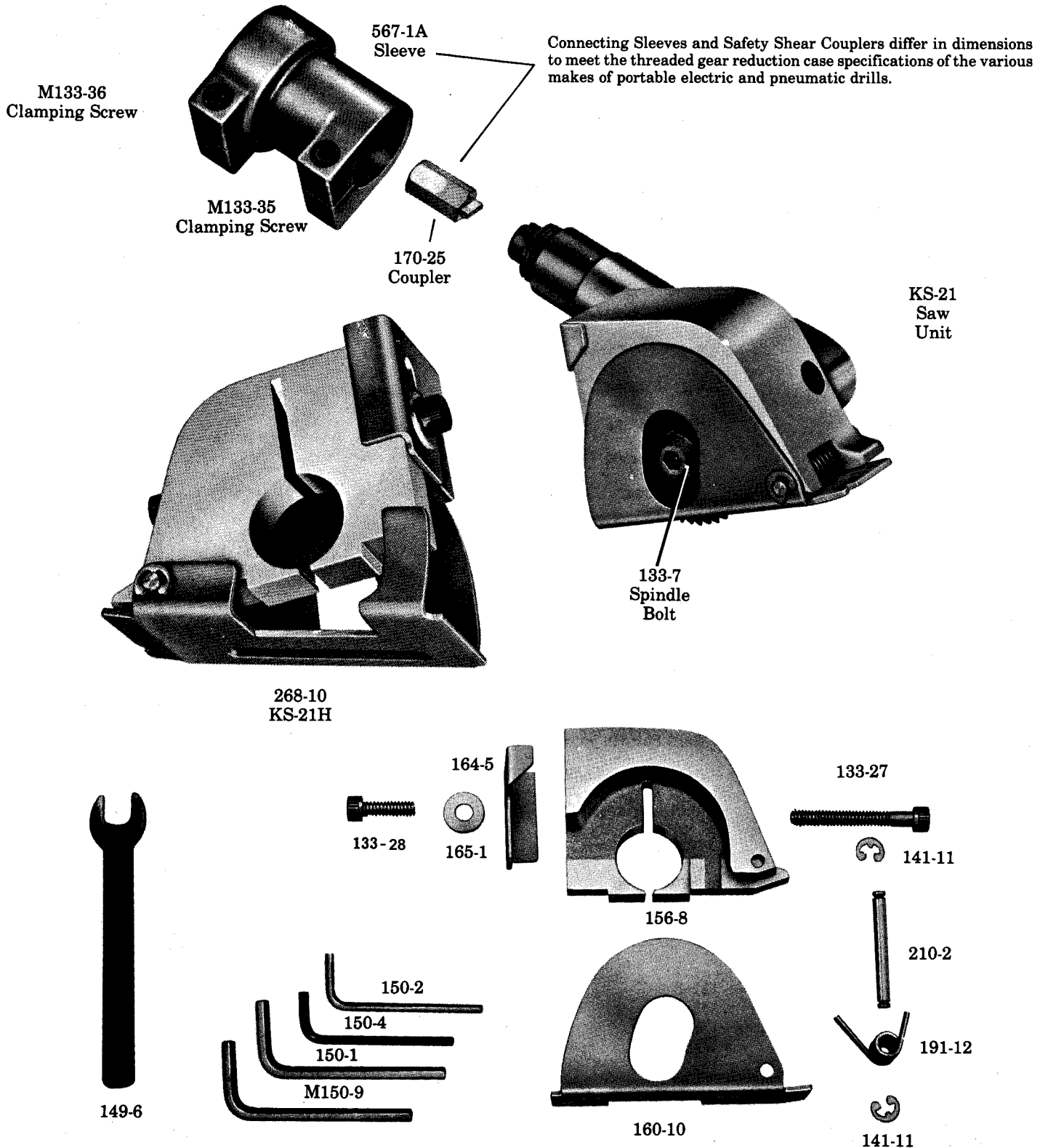

Connecting Sleeves and Safety Shear Couplers differ in dimensions to meet the threaded gear reduction case specifications of the various makes of portable electric and pneumatic drills.

PART NO.	DESCRIPTION	PART NO.	DESCRIPTION	PART NO.	DESCRIPTION
133-3	Clamping Screw	150-2	1/8" Socket Key	165-1	Spacer Washer
133-28	Depth Stop Screw	150-4	5/32" Socket Key	170-25	Safety Shear Coupler
133-27	Clamping Screw	M150-9	4MM Socket Key	191-12	Coil Spring
141-11	Retaining Ring	156-8	Saw Body	210-2	Guard Pin
149-6	Spindle Wrench	160-10	Saw Guard	268-10	Guard Assembly
150-1	3/16" Socket Key	164-5	Depth Stop	567-1A	Connecting Sleeve

PARTS LIST

KRA-2M HEAVY DUTY RIGHT ANGLE HEAD

This service sheet applies to those heavy duty right angle heads bearing serial number 6896 and higher as well as those bearing the letter M in conjunction with any serial number.

<u>Part Number</u>	<u>Description</u>
126-3	Drive Spindle
127-14	Bearing Retaining Screw
127-8	Retaining Screw
129-1	Ball Bearing
129-6	Ball Bearing
129-16	Ball Bearing
131-22	Mitre Gear
132-9	Shim Washer
138-5	Hex Nut
139-10	Drill Spindle
151-2	Housing
153-1	Bearing Sleeve
154-2	Drive Spindle Spacer
154-15	Drill Spindle Spacer
176-1	Grease Slinger Washer
177-1	Woodruff Key
178-1	Gear Set Screw
181-2	Screw Plug

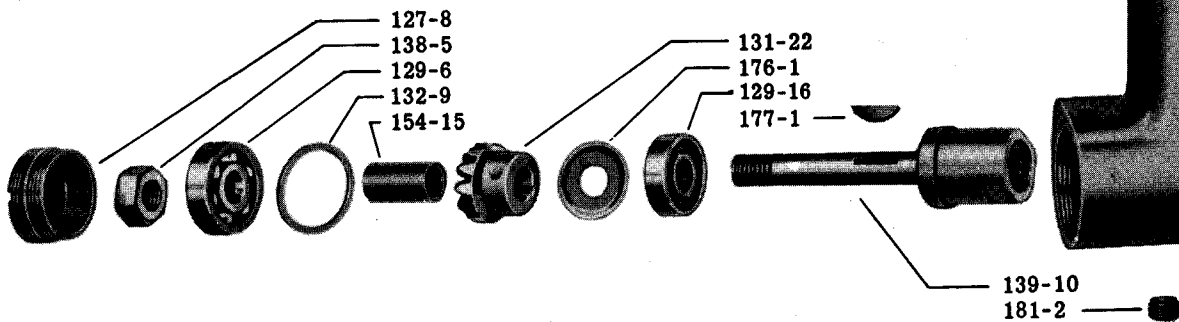
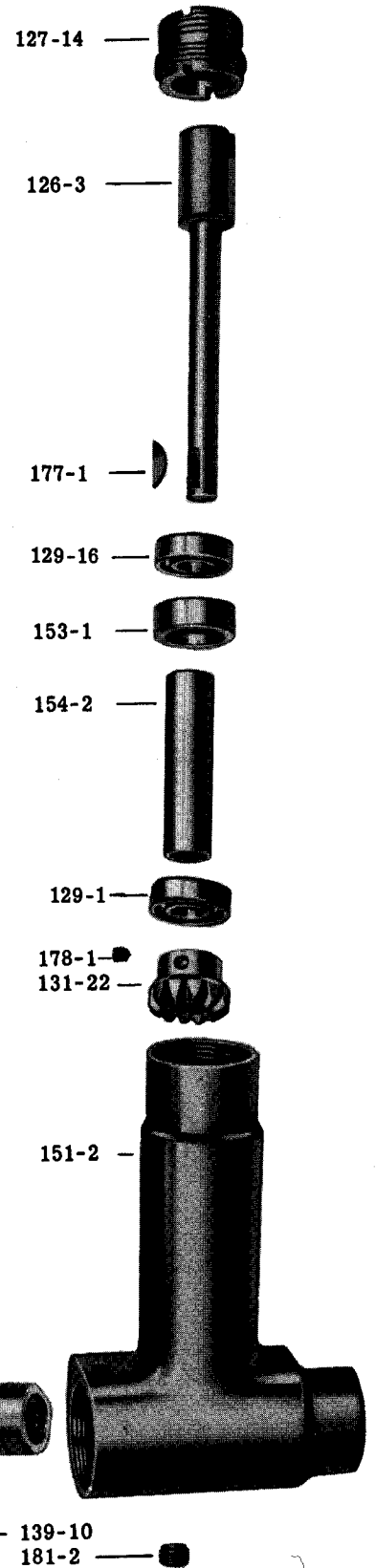

THE KETT TOOL CO. 5055 Madison Rd. CINCINNATI, OHIO 45227
 TEL. (513) 271-0333



Component Motor Unit Model 253-59

Used on KD-400, KD-480, KD-440, KD-441, KD-442, KD-1493 and KD-1495 Shears
 KS-421, KS-423, KS-424, KS-426 and KSV-432 Saws

PARTS LIST

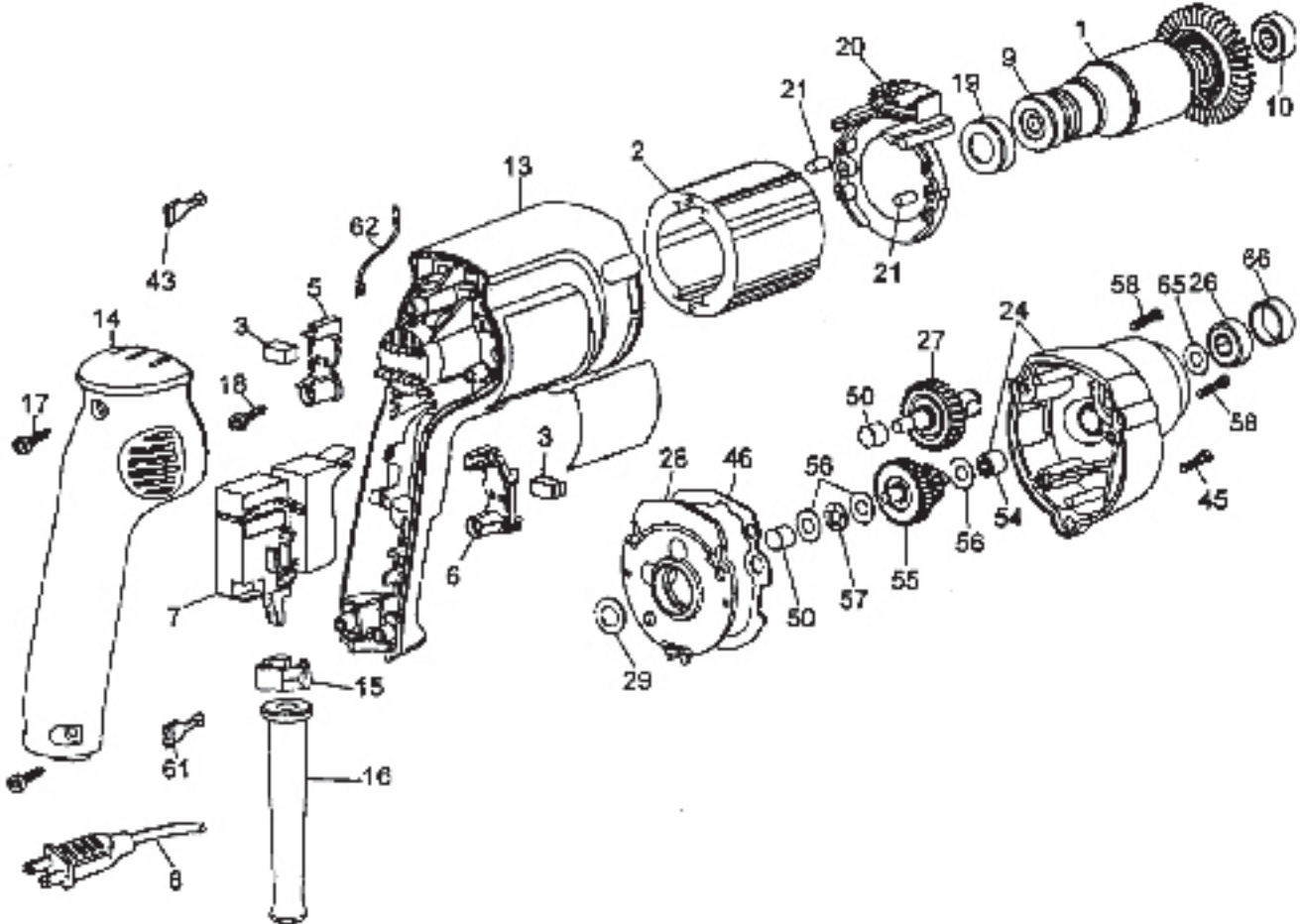

ITEM NO.	PART NO.	DESCRIPTION	REQ'D TOOL	ITEM NO.	PART NO.	DESCRIPTION	REQ'D TOOL
1	382299-01	Armature & Fan (6 Teeth)	1	*50	93128-00	Needle Bearing	2
2	176883-00	Field	1	*54	93129-00	Needle Bearing	1
3	176846-02	Brush	2	55	176731-00	Pinion & Gear (15/37 teeth)	1
5	176801-02	Left Brush Holder (gray)	1	56	176732-00	Thrust Washer	3
6	176800-02	Right Brush Holder (black)	1	57	143079-00	Thrust Washer	1
*7	176830-39	Switch	1	*58	330019-16	Screw	2
*7	621884-04	Switch	1	61	136086-08	Terminal	2
*8	330072-98	Cord & Plug (18-2SJ)	1	62	176860-00	Lead	1
*9	176950-00	Ball Bearing	1	65	449892-00	Washer	1
*10	176950-00	Ball Bearing	1	66	449368-00	Bearing Cap	1
13	396969-09	Field Case	1				
14	176899-02	Handle Cover	1				
*15	176829-00	Cord Clamp	1				
16	330005-01	Cord Protector	1				
*17	330019-13	Screw	3				
*18	176951-00	Screw	2				
*19	389824-00	Cup	1				
20	176811-01	Baffle	1				
21	949638-02	Rubber Plug	2				
*24	388657-00	Gear Case	1				
*26	330003-09	Ball Bearing	1				
27	388668-00	Spindle & Gear	1				
*28	176650-00	Gear Case Cover	1				
*29	23813-00	Fiber Washer	1				
43	136086-02	Terminal	4				
*45	330019-14	Screw	1				
46	176655-00	Gasket	1				

***NOTES:**

- 7 Use Switch 176830-39 for tools made before 11-25-2009 and 621884-04 on tools made after 11-25-2009.
- 8, 15 Cord clamp should be positioned, so that 30mm of cord jacket extends above the clamp.
- 9 Seal to face commutator. Press to the tubing on armature shaft.
- 10 To remove from shaft, place bearing in vise and crush outer race. Remove all internal bearing components, so that the inner race is all that is left. Use SRT320, Small Bearing Separator, to clamp the inner race and press off. Bearing presses to shoulder.
- 17,45,58 Torque to 18-23 inch-lbs.
- 18 Torque to 13 inch-lbs.
- 19 Small diameter end to face commutator. Lightly lubricate before installing into field case.
- 26 Press Bearing until seated completely in pocket. Rubber seal to face spindle and gear assembly.
- 28 Includes 10 and 50.
- 29 Press to bearing (item 10).
- 54 Press flush with surface facing spindle and gear assembly.



Operation & Maintenance of KETT Portable Power Panel Cutting Saws

KETT Panel Cutting Saws are available in models that range in cutting capacity from $\frac{1}{4}$ " up to a full 1" depth of cut. Blades for this selection of Saw Models start at $1\frac{1}{4}$ " and go thru to $3\frac{3}{8}$ " in diameter. The KETT Saws and Blades are designed for many uses such as cutting mild steel 16 gage and lighter, hard tempered aluminum and brass up to $\frac{1}{8}$ ", soft aluminum up to $\frac{3}{16}$ ", FRP plastics and plastic laminates up to $\frac{5}{8}$ ". Plywood, particle board, pressed board and similar soft rigid materials can be worked with ease. KETT Saws are especially effective on metal laminated sandwich type wall paneling as Alliance Wall, Color Wall, Mirawal, Porc-Lin Ply, Chalkboard and similar products.

KETT Saws like any good tools are well made and will give satisfactory service when used with care and given occasional preventive maintenance. Bear in mind the proper KETT Saws when used with factory recommended blades are suitable for cutting cold rolled sheet steel up to 16 gage. We do not recommend the saws for stainless steel nor titanium. To exceed this rated capacity invites excessive blade wear and breakage and damage to the motor by overtaxing the tool. See the application recommendations on the KETT Saw Blade price sheet and by all means **Read and heed the safety rules which accompany each tool.**

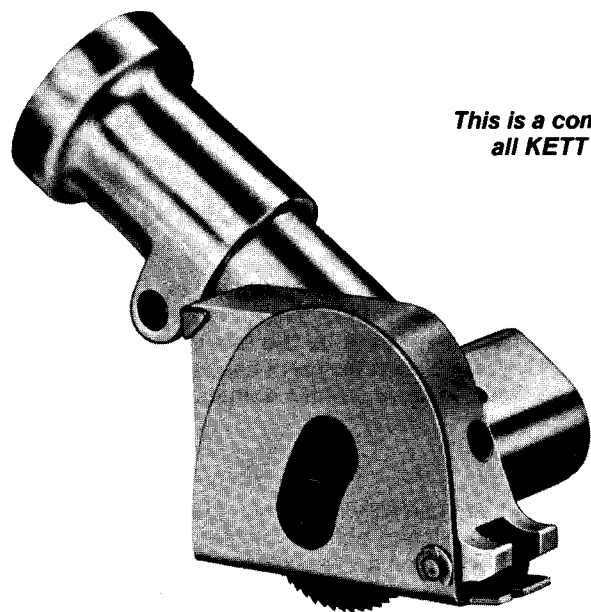

This is a composite of all KETT saw units

Adjustments

Before making any adjustments to the saw be certain it is disconnected from the power source.

To adjust the angle of the saw body on the Geared Right Angle Head loosen the socket head clamping screw in the saw body and turn saw body to desired position, being careful to keep the saw blade centered in the slot and in line with the vee sight of the saw guard, then tighten the clamping screw.

To adjust the angle of the Saw Unit in relation to the motor, loosen the socket head clamping screw in the sleeve, twist saw unit to desired position, being careful to keep it at the same depth in sleeve, so as not to disengage coupler then tighten the clamping screw.

To adjust for cutting depth, loosen the depth stop screw (or a knurled thumb nut that could be in its place) on rear of saw body, raise or lower depth stop as necessary until blade is properly exposed to desired penetration, then tighten. Ordinarily the saw should be extended approximately $\frac{1}{16}$ " to $\frac{1}{8}$ " more than the thickness of the material being cut. When cutting through a panel supported by ribs or other understructure that should be unmolested, extend blade to the same distance as the measured thickness of the material being cut.

Replacing Blades

To replace blade on the KETT Saw insert open end spindle wrench behind the blade and span the flats on the output spindle. Insert the socket key into the hex socket of the spindle bolt, loosen and remove both bolt and blade.

You will note the blade, which has a $\frac{7}{16}$ " bore, slips over the spindle and seats itself against the shoulder. This design provides for more concentricity resulting in smoother, faster and more accurate cutting. Slip the blade over the spindle, seat it against the shoulder, replace the spindle bolt and pull up tight. The smaller diameter blade with the $\frac{1}{4}$ " bore fits over the threaded shank of the spindle bolt and seats itself against the face of the output spindle.

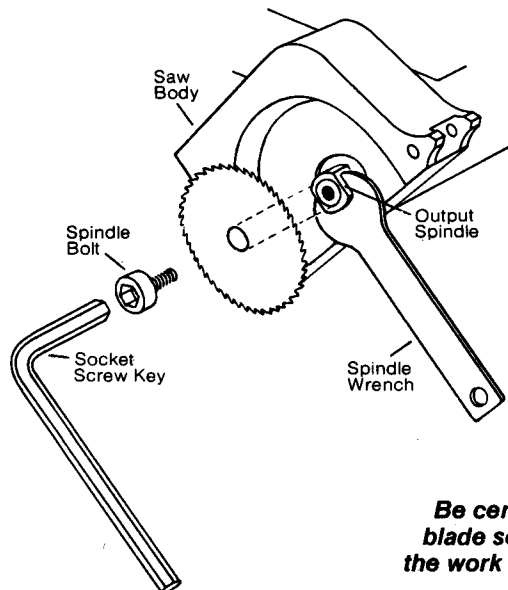

Be certain to insert the blade so the teeth enter the work pointing forward

Precaution Before Replacing Blades

Be certain there is no oil or grease or any particles of any kind on the face of the spindle, on the shoulder of the spindle or on either side of the blade. Be certain to wipe clean all these parts. Failure to follow this precaution will result in the blade slipping or standing stationary on the spindle when the saw is in operation.

Care of the Motor

Motors are packed with lubricant to give 300 hours service. At the end of this period the gear case and the armature bearings should be checked and more grease added if necessary. A good grade of gear grease is recommended.

A hot motor is a sign of trouble. It can easily lead to a burnt out armature. **Stop the tool and determine the cause.** Overheating is due to overloading beyond capacity; low voltage, due to faulty connections or the use of extensions of light wire gage (the extension itself will tend to overheat), poor ventilation thru motor case; or bad brushes. **It is good practice to check brushes every two weeks. Chipped brushes or brushes shorter than $\frac{1}{8}$ " should be replaced.**

The tool is equipped with an approved three conductor cord and three prong grounding type plug to fit the proper grounding type 120VAC receptacle. This green ground wire connection on the cord and at the plug is there for your own safety. **Please use it.** It is especially important that the tool be grounded when there is the slightest trace of dampness present. **Precaution! Always check the line voltage before plugging in your saw.**

These instructions exclude **DOUBLE INSULATED TOOLS** when referring to brush length and three wire conductor.

Care of the KETT Saw

A light, compact unit such as the KETT Saw necessarily has small gears and shafts. Extremely rugged for its size, the KETT Saw is more than adequate for normal use. However, as with all fine tools, care is essential for long life and best performance. Skillful operation depends on a certain amount of practice, easily acquired, but very important. The saw spindle and gears should be lubricated after every 25 to 30 hours use. Injecting a light cup grease into the grease opening covered by screw plug #181-2. Two ounce tubes are available from stock. Specify 264-1 two ounce tube Non-Fluid Oil. **MAKE A VISUAL CHECK FOR DAMAGE BEFORE OPERATING TO BE CERTAIN SAW IS SAFE TO USE.**

Cutting with the KETT Saw

Feed Blade into material gradually to avoid sudden strain. When blade starts cutting, it is better to "crowd" the rate of feed to attain a steady cutting speed rather than to hold back. Where conditions permit, blade life can be extended through the use of a lubricant such as cutting oil, wax, tallow, or a grease stick. It is recommended to practice cutting with the KETT Saw on scrap material until knack of using tool is acquired.

Starting Cut from Edge of Material

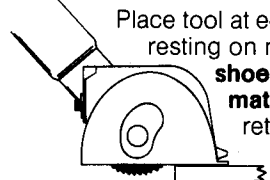

Place tool at edge of material with front of shoe only resting on material. **Make sure tool is held with shoe flat and level with surface of material.** The guard should be in its retracted position to expose the blade. Point tool in direction of cut lining up scribed line in vee sight on saw guard. Squeeze the trigger switch and set the blade in motion. Slowly push tool forward until blade starts to cut, gradually increasing pressure until blade is cutting full depth. Then increase pressure until tool moves forward at a uniform rate depending on material being cut. Do not jerk or thrust tool. **DO NOT REMOVE SAW GUARD, BE CERTAIN THAT SAW GUARD IS FIRMLY IN PLACE BEFORE STARTING.**

Starting Plunge Cut in Center of Sheet

CAUTION: Use a sharp blade.

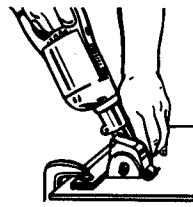

Position — The tool is held in upright position while you bring the blade into perfect starting alignment. The guard only is against the panel — the blade cannot accidentally mar the surface.

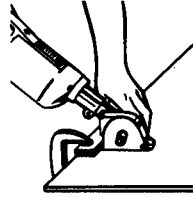

Plunge — The handle is lowered pushing the blade into the panel exactly where you want it — starting the cut. The back stop shown prevents any tendency of backward movement when plunging.

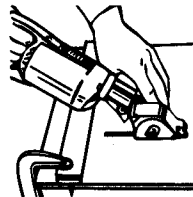

Saw with Ease — The guard rides smoothly over the panel surface as you continue cutting your pattern. When the cut is finished, the guard automatically drops down to cover the blade.

Continuing the Cut

Make sure the shoe stays flat against material being cut. If not kept flat, blade may fail to penetrate or may be pinched and broken. The shoe is designed to keep chips from getting under and marring the work. If the saw guard does seem to mar the surface of the material being cut, this can be overcome by either running the cut on the reverse side of the material or by covering the section to be cut with a pressure sensitive tape, then running the saw over and cutting thru the tape.

Stopping the Cut and Removing the Saw

Bring the saw up to the ending point of the cut, hold firmly, shut off power and let it coast to a full stop. Then lift the saw from the cut. **Never back up the tool in the cut with the power on. This is the most frequent cause of broken blades and can result in more serious damage to the tool.**

Guarantee

Each tool has been carefully inspected and tested before shipping. Before attempting to put tool into service it is imperative to read the operation and maintenance manual as well as the safety rules.

Our obligation assumed under this guarantee is limited to making repairs to any tools or any parts of our manufacture returned to our factory at our option, transportation prepaid, which prove to our satisfaction upon examination to have been defective and have not been misused, abused or carelessly handled.

We reserve the right to decline responsibility where repairs have been made or attempted by others.

This guarantee does not apply to expendable parts such as saw blades, shear cutters, safety shear couplers, brushes, and auger bits.

No other guarantee, written or verbal, is authorized by us.

Important: You must fill out and mail Registry Card or Guarantee is Void



5055 Madison Road
Cincinnati, Ohio 45227
(513) 271-0333