

COMPONENT PARTS OF KS-23 SAW UNIT

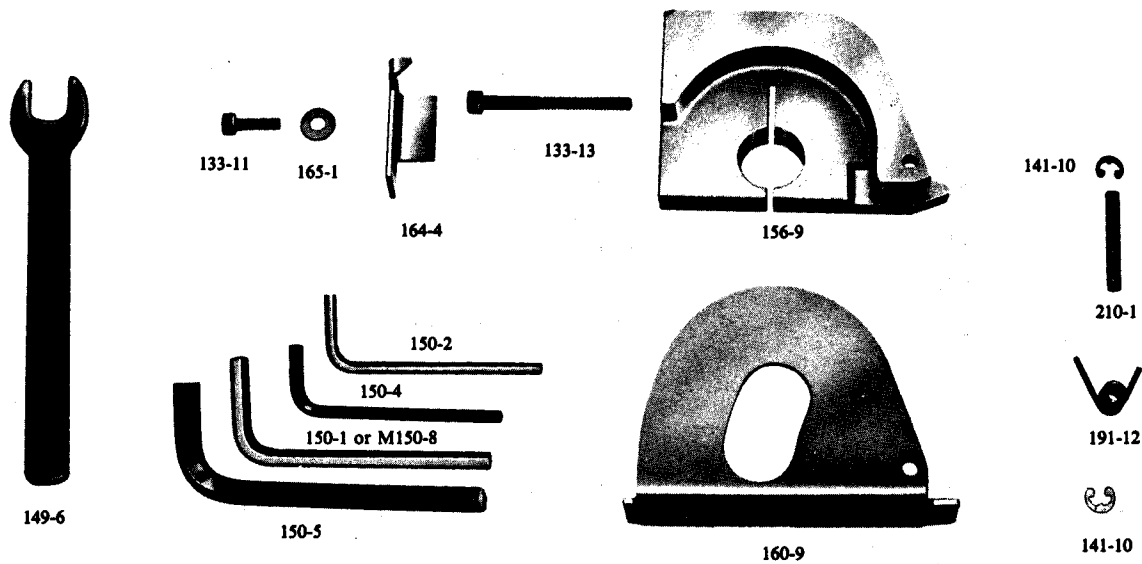
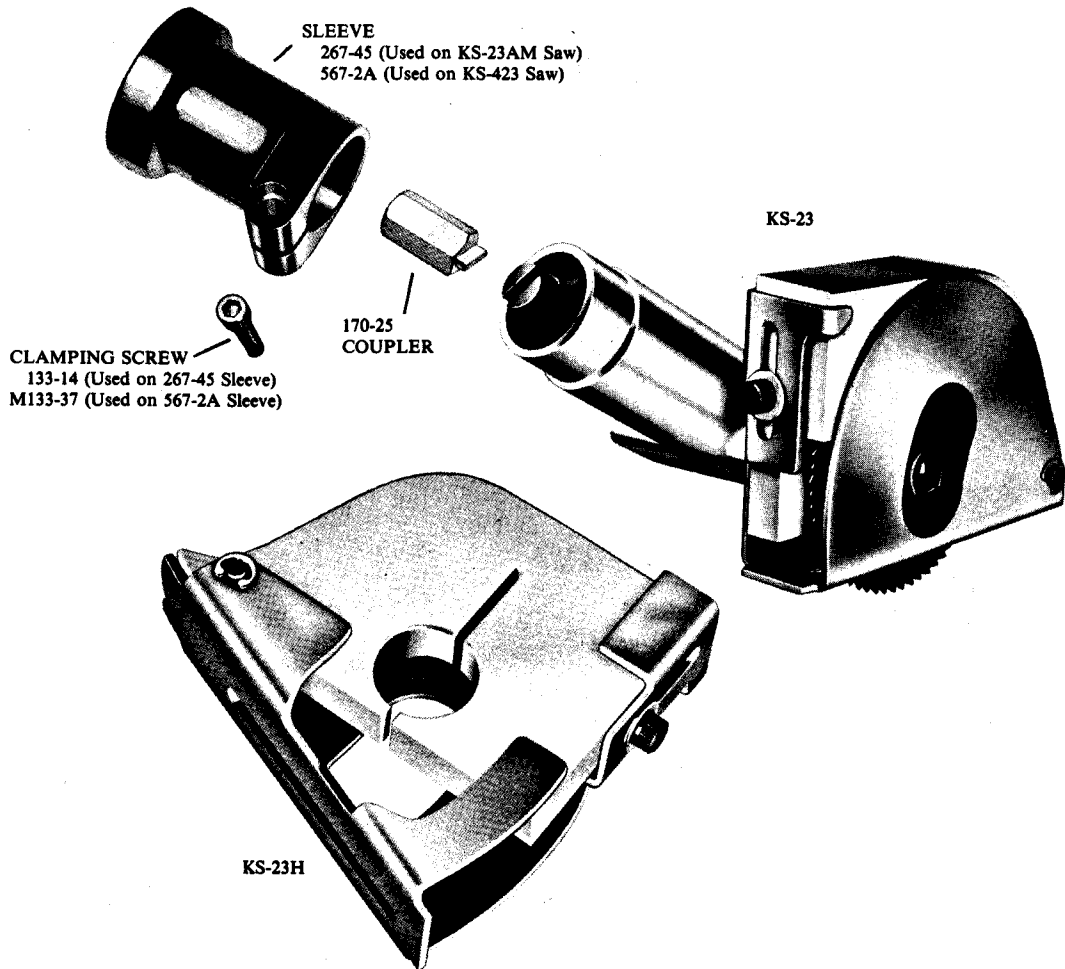

Part No.	Description	Part No.	Description	Part No.	Description
133-11	Socket Head Cap Screw	150-2	1/8" Socket Key	165-1	Spacer Washer
133-13	Clamping Screw for 156-9	150-4	5/32" Socket Key	170-25	Safety Shear Coupler
133-14	Clamping Screw for 267-45	150-5	5/16" Socket Key	191-12	Coil Spring
M133-37	Clamping Screw for 567-2A	M150-8	5MM Socket Key	210-1	Guard Pin
141-10	Retaining Ring	156-9	Saw Body	267-45	Connecting Sleeve for KS-23AM Saw
149-6	Spindle Wrench	160-9	Saw Guard	268-9	KS-23H Saw Body & Guard Assembly
150-1	3/16" Socket Key	164-4	Depth Stop	567-2A	Connecting Sleeve for KS-423 Saw

KETT TOOL CO.

5055 Madison Road

CINCINNATI, OHIO 45227-1494

COMPONENT PARTS FOR KRA-5 GEARED ANGLE HEAD

(Serial Number 15241 & Higher)

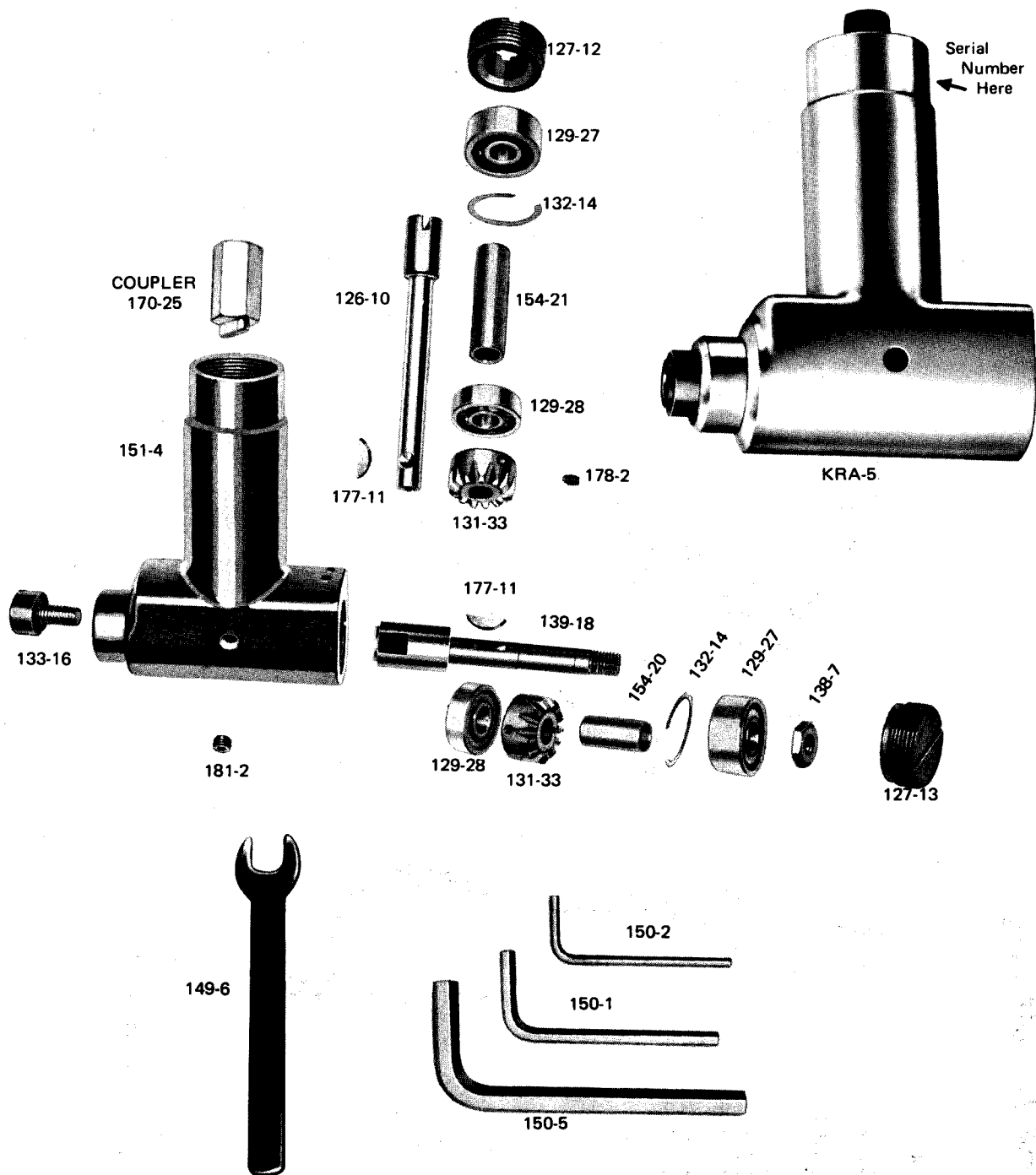

Part No.	Description	Part No.	Description	Part No.	Description
126-10	Input Spindle	133-16	Spindle Bolt	151-4	Housing
127-12	Retaining Screw	138-7	Jam Nut	154-20	Sleeve
127-13	Retaining Screw	139-18	Output Spindle	154-21	Sleeve
129-27	Ball Bearing	149-6	Spindle Wrench	170-25	Coupler
129-28	Ball Bearing	150-1	3/16 Socket Key	177-11	Woodruff Key
131-33	Mitre Gear	150-2	1/8 Socket Key	178-2	Socket Head Set Screw
132-14	Shim	150-5	5/16 Socket Key	181-2	Screw Plug
133-14	Clamping Screw				

KETT TOOL CO. 5055 Madison Road
 TELEPHONE: (513) 271-0333

CINCINNATI, OHIO 45227-1494
 FAX: (513) 271-5318