

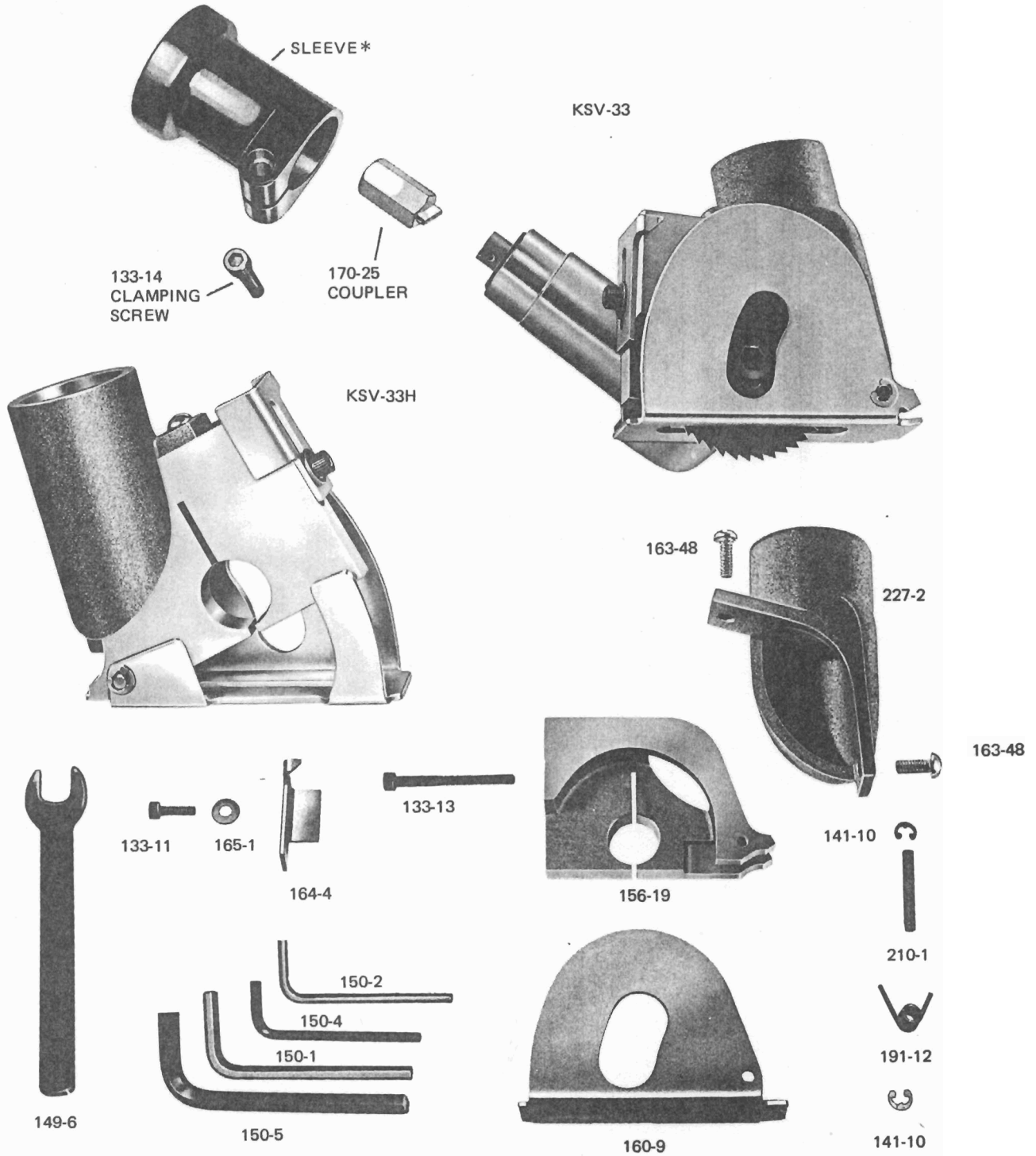

# COMPONENT PARTS OF KSV-33 SAW UNIT

\*Use 267-45 Sleeve on KSV-33AM Saw

\*Use 567-2A Sleeve on KSV-32AM, KSV-432 and PSV-532 Saws



Part No.	Description	Part No.	Description	Part No.	Description
133-11	Socket Head Cap Screw	150-5	5/16" Socket Key	210-1	Guard Pin
133-13	Clamping Screw	156-19	Vacuum Saw Body	227-2	Vac Head
133-14	Clamping Screw	160-9	Saw Guard	267-45	Connecting Sleeve
141-10	Retaining Ring	163-48	Screw 10-24 x 1/2"	268-18	KSV-33H Saw Body & Guard Assembly
149-6	Spindle Wrench	164-4	Depth Stop	567-2A	Connecting Sleeve
150-1	3/16" Socket Key	165-1	Spacer Washer		
150-2	1/8" Socket Key	170-25	Safety Shear Coupler		
150-4	5/32" Socket Key	191-12	Coil Spring		

