

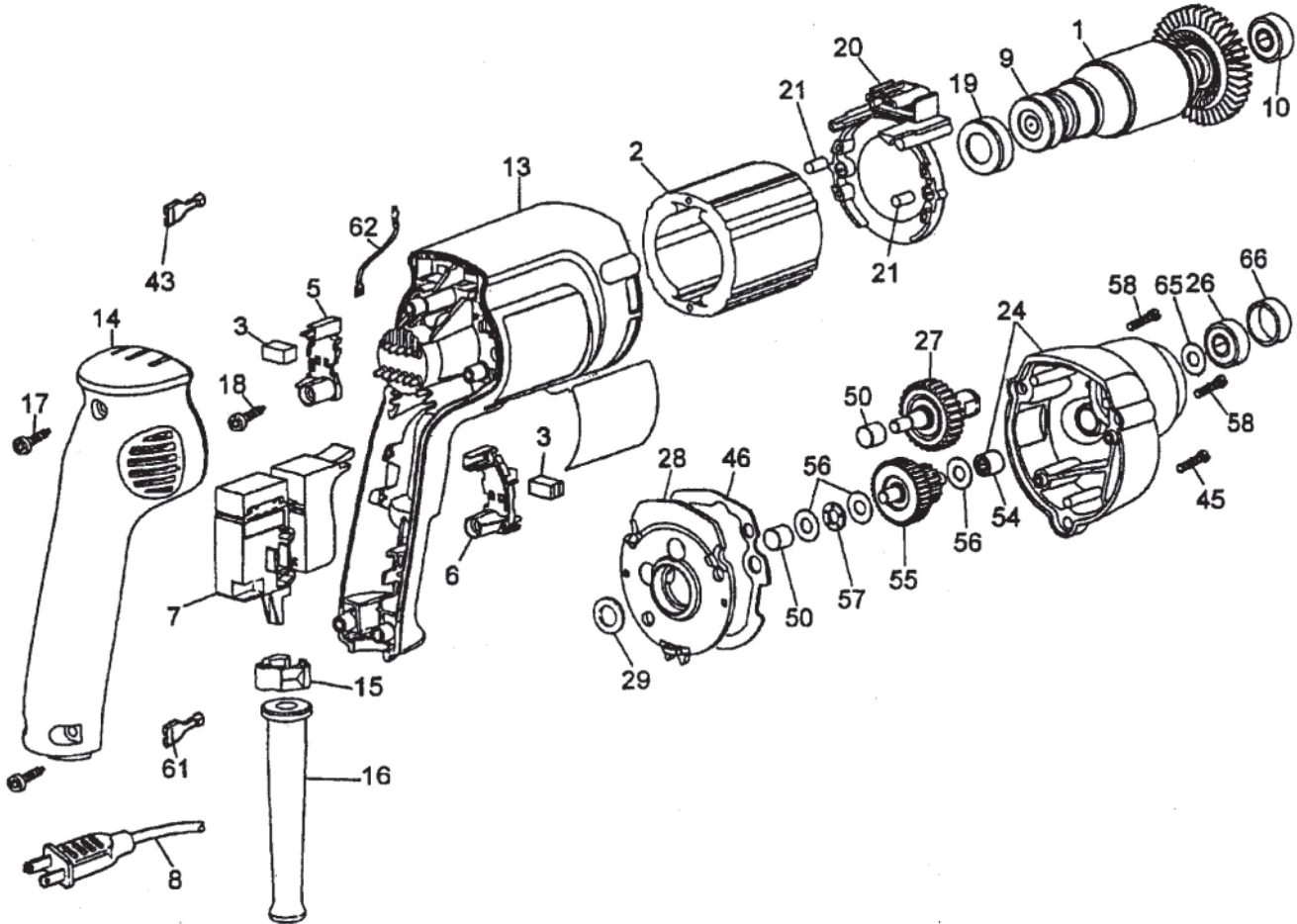

Component Motor Unit Model 253-59

Used on KD-440, KD-441, KD-442, KD-493 and KD-495 Shears
 KS-423, KS-424, KS-426 and KSV-432 Saws

PARTS LIST



ITEM NO.	PART NO.	DESCRIPTION	REQ'D TOOL	ITEM NO.	PART NO.	DESCRIPTION	REQ'D TOOL
1	382299-01	Armature & Fan (6 Teeth)	1	*54	93129-00	Needle Bearing	1
2	176883-00	Field	1	55	176731-00	Pinion & Gear (15/37 teeth)	1
3	176846-02	Brush	2	56	176732-00	Thrust Washer	3
5	176801-02	Left Brush Holder (gray)	1	57	143079-00	Thrust Washer	1
6	176800-02	Right Brush Holder (black)	1	*58	330019-16	Screw	2
7	176830-39	Switch	1	61	136086-08	Terminal	2
*8	330072-98	Cord & Plug (18-2SJ)	1	62	176860-00	Lead	1
*9	176950-00	Ball Bearing	1	65	449892-00	Washer	1
*10	176950-00	Ball Bearing	1	66	449368-00	Bearing Cap	1
13	396969-09	Field Case	1	*NOTES: 8, 15 Cord clamp should be positioned, so that 30mm of cord jacket extends above the clamp. 9 Seal to face commutator. Press to the tubing on armature shaft. 10 To remove from shaft, place bearing in vise and crush outer race. Remove all internal bearing components, so that the inner race is all that is left. Use SRT320, Small Bearing Separator, to clamp the inner race and press off. Bearing presses to shoulder. 17,45,58 Torque to 18-23 inch-lbs. 18 Torque to 13 inch-lbs. 19 Small diameter end to face commutator. Lightly lubricate before installing into field case. 26 Press Bearing until seated completely in pocket. Rubber seal to face spindle and gear assembly. 28 Includes 10 and 50. 29 Press to bearing (item 10). 54 Press flush with surface facing spindle and gear assembly.			
14	176899-02	Handle Cover	1				
*15	176829-00	Cord Clamp	1				
16	330005-01	Cord Protector	1				
*17	330019-13	Screw	3				
*18	176951-00	Screw	2				
*19	389824-00	Cup	1				
20	176811-01	Baffle	1				
21	949638-02	Rubber Plug	2				
*24	388657-00	Gear Case	1				
*26	330003-09	Ball Bearing	1				
27	388668-00	Spindle & Gear	1				
*28	176650-00	Gear Case Cover	1				
*29	23813-00	Fiber Washer	1				
43	136086-02	Terminal	4				
*45	330019-14	Screw	1				
46	176655-00	Gasket	1				
*50	93128-00	Needle Bearing	2				



COMPONENT PARTS OF KSV-33 SAW UNIT

*Use 267-45 Sleeve on KSV-33AM Saw

*Use 567-2A Sleeve on KSV-32AM, KSV-432 and PSV-532 Saws

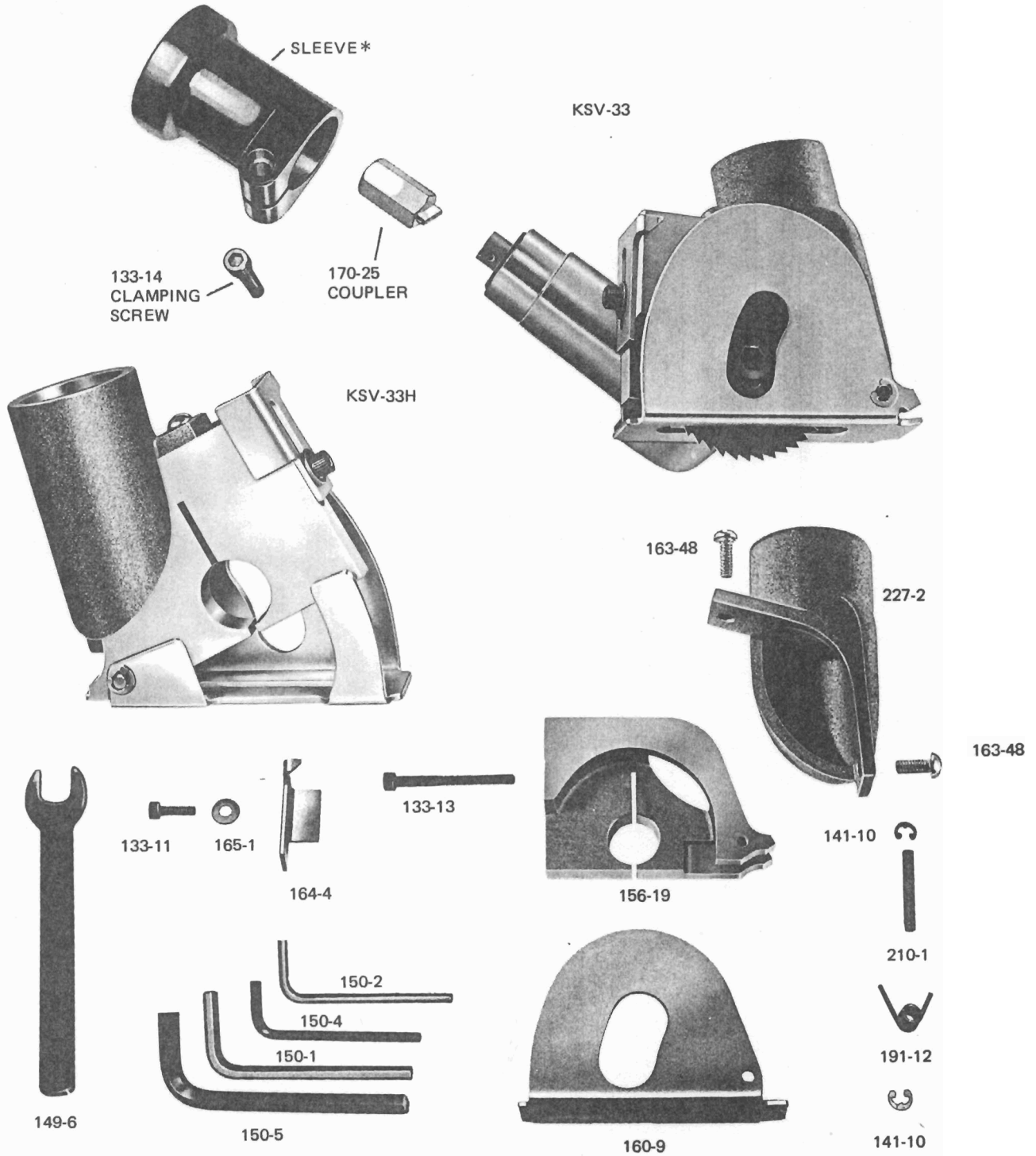

Part No.	Description	Part No.	Description	Part No.	Description
133-11	Socket Head Cap Screw	150-5	5/16" Socket Key	210-1	Guard Pin
133-13	Clamping Screw	156-19	Vacuum Saw Body	227-2	Vac Head
133-14	Clamping Screw	160-9	Saw Guard	267-45	Connecting Sleeve
141-10	Retaining Ring	163-48	Screw 10-24 x 1/2"	268-18	KSV-33H Saw Body & Guard Assembly
149-6	Spindle Wrench	164-4	Depth Stop	567-2A	Connecting Sleeve
150-1	3/16" Socket Key	165-1	Spacer Washer		
150-2	1/8" Socket Key	170-25	Safety Shear Coupler		
150-4	5/32" Socket Key	191-12	Coil Spring		

COMPONENT PARTS FOR KRA-5 GEARED ANGLE HEAD

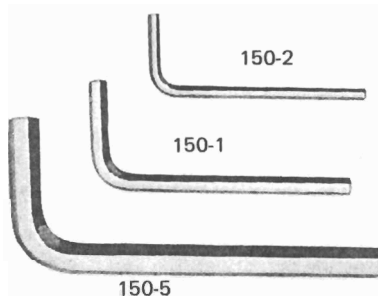
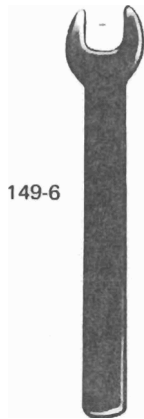
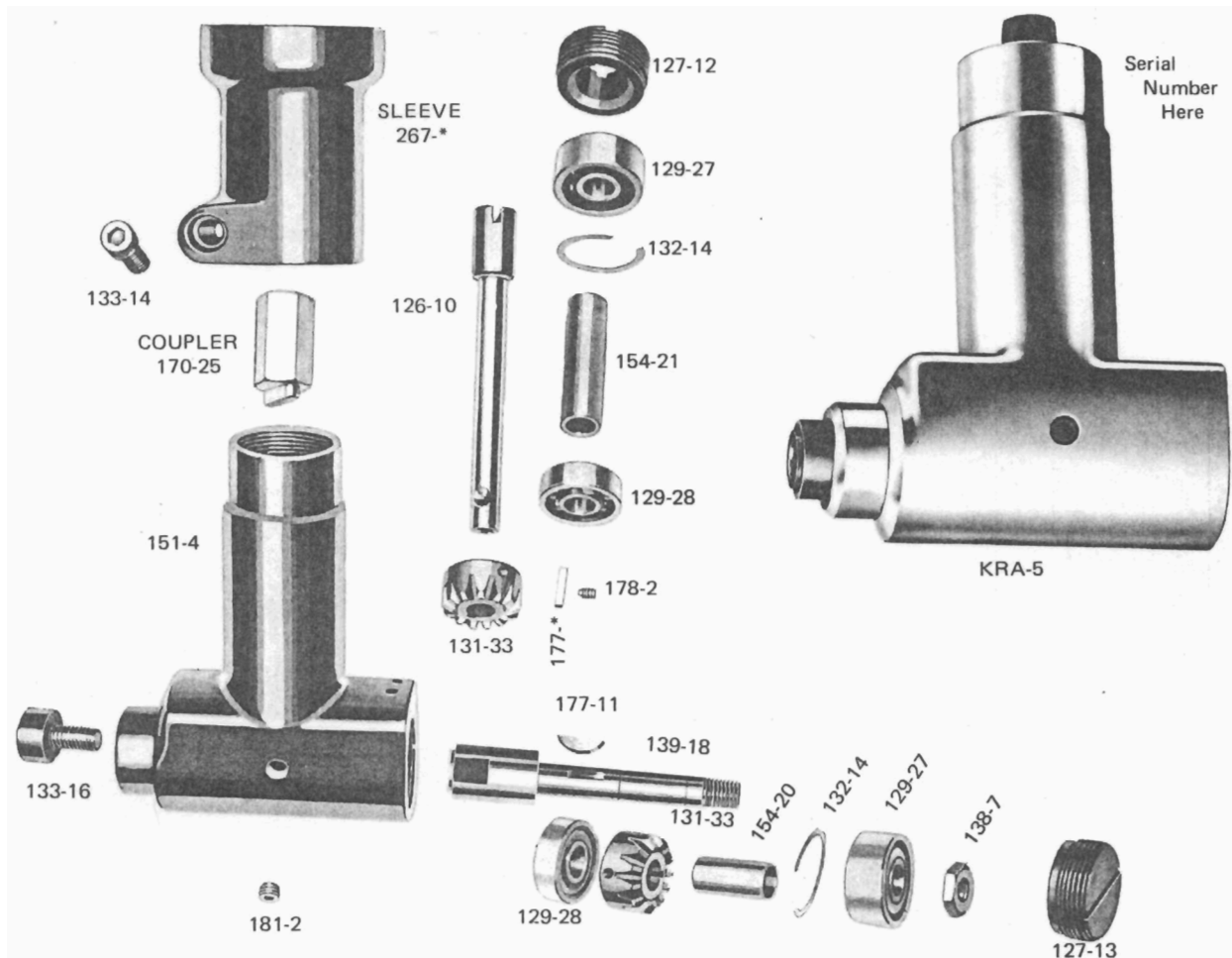

Part No.	Description	Part No.	Description	Part No.	Description
126-10	Input Spindle	139-18	Output Spindle		S/N 15240 & lower use
127-12	Retaining Screw	149-6	Spindle Wrench		177-7 Square Key,
127-13	Retaining Screw	150-1	3/16 Socket Key		S/N 15241 & higher use
129-27	Ball Bearing	150-2	1/8 Socket Key		177-11 Woodruff Key
129-28	Ball Bearing	150-5	5/16 Socket Key	177-11	Woodruff Key
131-33	Mitre Gear	151-4	Housing	178-2	Socket Head Set Screw
132-14	Shim	154-20	Sleeve	181-2	Screw Plug
133-14	Clamping Screw	154-21	Sleeve	267-*	Sleeve (See reverse
133-16	Spindle Bolt	170-25	Coupler		side of sheet for
138-7	Jam Nut	177-*	Key (See serial number on neck of KRA-5 above)		Sleeve information)

THE KETT TOOL CO. 5055 Madison Road CINCINNATI, OHIO 45227
 TELEPHONE: (513) 271-0333